

Flow Measurement of Bulk Solids with Microwave-Technology

Application and Function

The solid flow meter DYNA M-flow is designed for flow measurement in metallic pipes from a few kg/h to many t/h. The system is suitable for on-line measurement of powders, dust, pellets and granulate in pneumatic conveying or free fall applications.

The measurement principle of the DYNA M-flow is based on the physical Doppler-effect, whereas the sensor generates a uniform field in the microwave frequency range inside the pipe. These microwaves are being reflected by particles passing through the pipe. Calculation of frequency and amplitude changes allows an accurate determination of the mass flow rate. Non-moving particles like dust accumulation are excluded from calculations.

Technical Data Sensor

material	antenna	stainl. steel 1.4571 (AISI 316Ti)
	isolation	polyamide (PA 6.6)
	process coupling	welding branch stainl. steel 1.4571 (AISI 316Ti)
ambient cond.	temperature	-20°C...+70°C (-4°F...158°F)
	degree of protection	IP 65 (EN 60529)
	EMC	according to EN 61326-1

Technical Data Evaluating Unit

	design	DIN-rail 22.5 mm
	supply voltage	18...31 V DC, 3 W
ambient cond.	temperature	-10°C...+60°C (14°F...140°F)
	degree of protection	IP 30 (EN 60529)
output	analog	0/4...20 mA (load < 750 Ohm)
		0/2...10 V
	digital	pulse as open collector alarm relay 30 V AC/DC; 0.5 A
	interfaces	RS 232 und RS 485

Process Data

process cond.	temperature	-20°C...+90°C (opt.+150/450°C)
	Pressure	max. 6 bar (opt. 25 bar)
	particle size	0.01 µm ... 20 mm
	pipe cross section	max.300 mm (16", higher on request)
	mass flow rate	min.1 kg/h



Characteristics

- ▶ For pneumatic conveyors and free fall processes
- ▶ IN-LINE measurement
- ▶ Easy installation, mounted flush with the inner pipeline wall
- ▶ Contact-less and wear-free
- ▶ Up to 24 products storable
- ▶ Robust and compact, long-term stable
- ▶ DIN-Rail Transmitter with COM-interface for direct online-connection
- ▶ Galvanically isolated RS485-Interface for PLC-connection
- ▶ Sensor supply for connections up to 1200 m
- ▶ Limit value monitoring with alarm contact
- ▶ Usual accuracy: +/- 1...4%

Options

- ▶ Approved for the use in ATEX zone 2/22
- ▶ Higher pressures on request
- ▶ Temperature up to +150/450°C (302/842°F)
- ▶ DYNAslect: Up to 6 products switchable via separate digital input



design

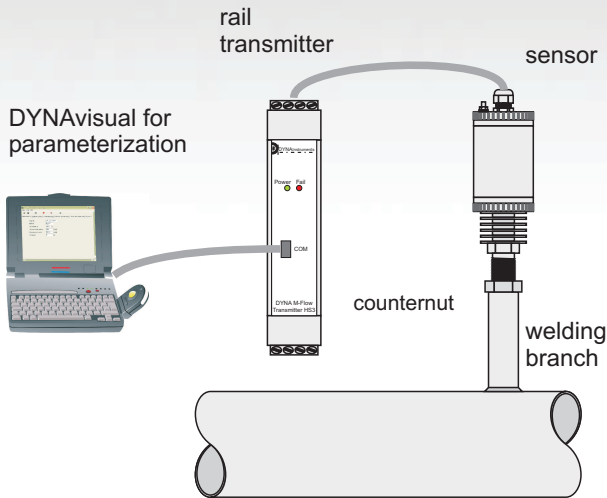

build-up and start-up

The flowmeter DYNA M-flow consists of a sensor, a transmitter (top-hat rail modul), a welding branch and the PC software DYNAvisual.

The sensor is installed by using the welding branch, through which a whole is drilled into the pipeline. The sensor is screwed into the welding branch until it is flush with the inner pipeline wall.

The device can be used in free fall applications or in vertical or horizontal pneumatic conveying systems.

The transmitter is connected with the sensor through a shielded 4-core cable and the following interfaces are available: Current output (4...20 mA), pulse output, error relay, RS232 and RS485.

For start-up and calibration the software DYNAvisual is used. A laptop can be connected easily via the COM interface at the front of the transmitter.

Calibration can be performed with either one or multiple reference flow amounts. Parameters for up to 24 different products can be saved.

The measurement value is output either through an analog (4...20 mA) or a digital signal.

transmitter

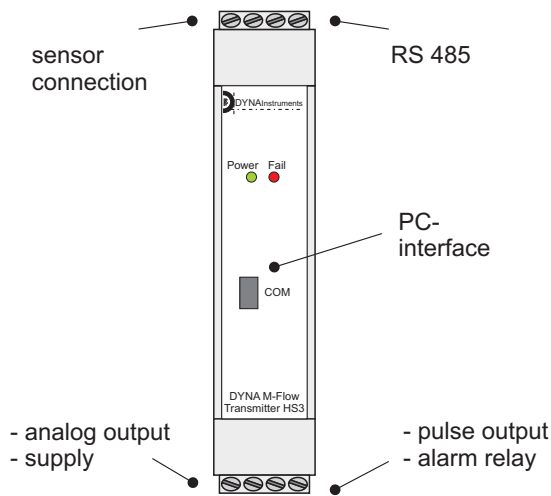

probe with welding branch

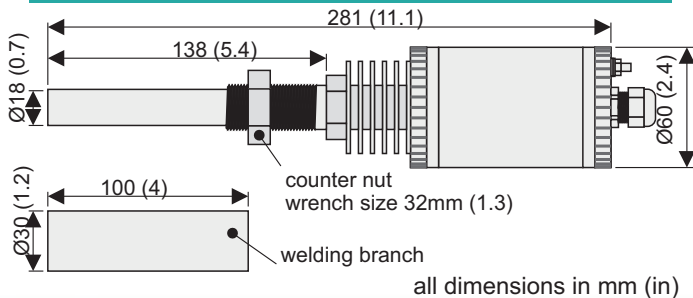

technical data subject to change without notice